

1 QubeCL lock-applications examples

1.1 Laser frequency lock to a spectroscopic line with LIA module

An easy way to stabilize the frequency of a laser is to lock its frequency to an atomic or molecular transition. An advantage of this method is that the optical transitions can be quite narrow, typically on the order of a few MHz, however, the thermal Doppler broadening will considerably increase the width of these transitions.

To avoid the Doppler broadening effect, an optical scheme such as the one shown in fig.1 can be used, saturation spectroscopy allows to achieve a sub-Doppler resolution in order to identify the central frequency of the transition with more precision.

The laser beam to be stabilized is divided into two parts using a beam splitter. Most of the laser radiation is transmitted and is called "pump" beam, a small fraction of the laser radiation is reflected and is called "probe" beam. The two beams have counter-propagating paths and overlap in the cell containing the reference gas. The probe beam is detected after the cell by a photodetector.

This configuration allows to identify the Lamb dip, result of the saturated absorption process, and using a common modulation spectroscopy technique it is possible to obtain the error signal for the laser frequency correction.

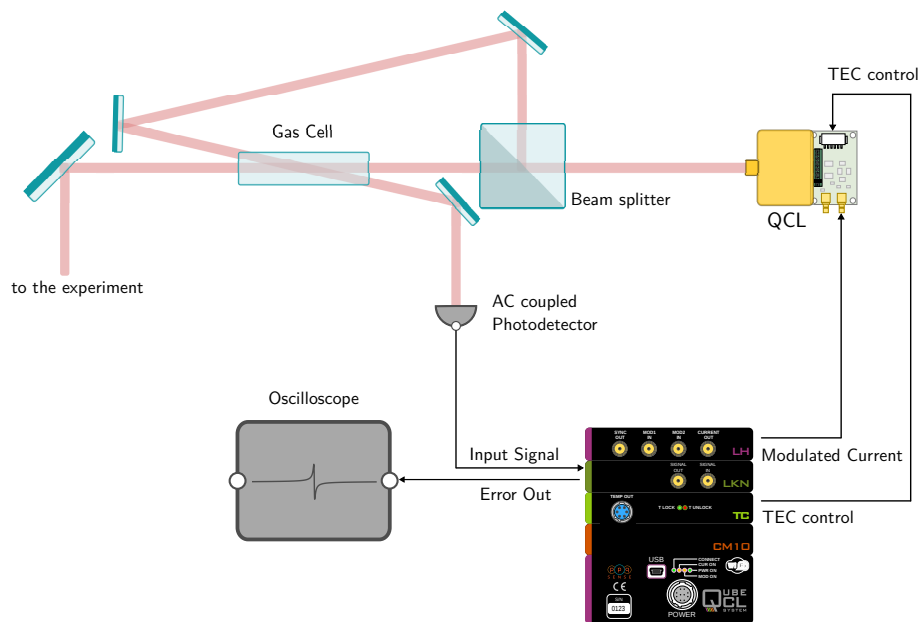

Figure 1: spectroscopic line lock using LIA module

Using the lock-in module (LIA) installed on the QubeCL System, it is possible to directly acquire the spectroscopy signal from the photodetector and apply the correction to the laser for frequency locking. In this configuration, the QubeCL is able to perform internally all the necessary operations to control the locking procedure:

1. Current modulation with frequency and amplitude control
2. Signal demodulation with amplification and integration-time control
3. Processing of the error signal by using a PID controller
4. Addition of the correction current directly to the laser bias current

The control software allows to keep under control all the parameters for the optimization of the locking procedure.

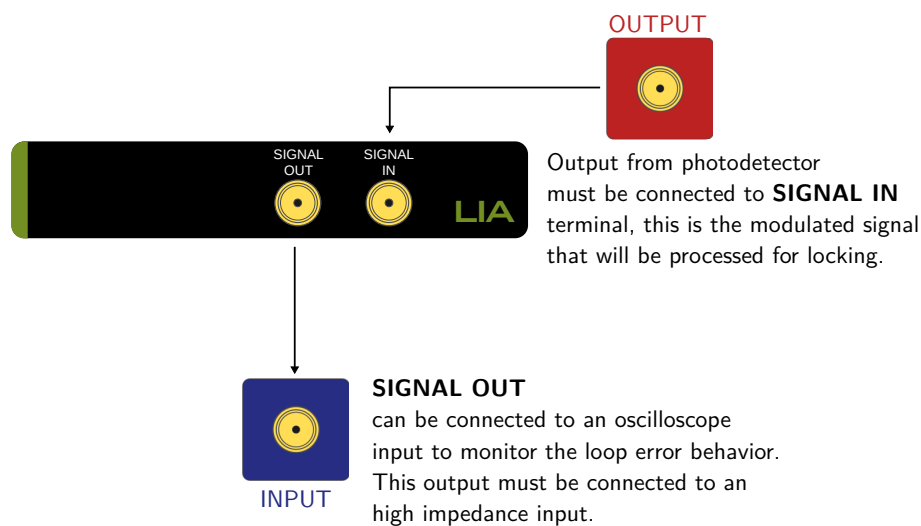

Figure 2: LIA terminals explanation

1.2 Offset phase lock with PLL module

Offset phase lock between two lasers is a technique for transferring the phase (and thus frequency, too) characteristics of a reference laser to a target laser. It is commonly used in spectroscopic applications and in metrology.

Fig.3 shows a possible optical scheme for the implementation of an offset phase lock between two Quantum Cascade Lasers (anyway the QubeCL System can work with any type of diode laser).

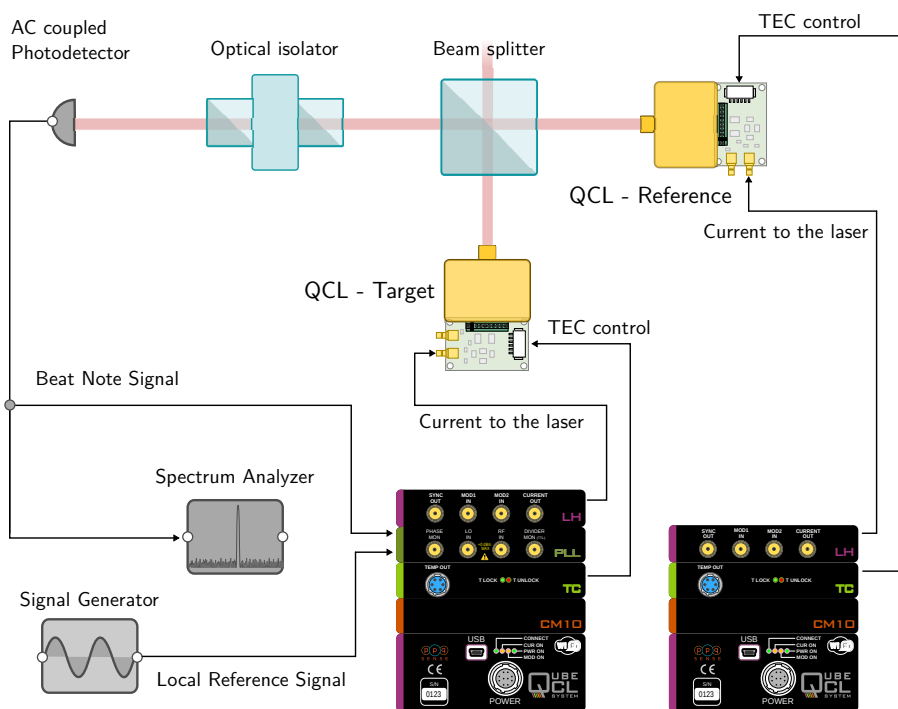

Figure 3: PLL laser lock setup

The reference laser radiation is superimposed on the target one using a beam splitter. The overlap of the beams is detected with a wide band photodetector and generates a beat signal at the frequency difference between the target and reference laser radiations, the beat-note frequency is usually in the hundreds of MHz range.

To perform an offset phase lock, the beat note is mixed with a local RF reference signal with frequency f_{offset} . At this point the signal obtained from this procedure will be constant only if the frequency difference between the target laser radiation and the reference one is exactly f_{offset} , this is the final error signal used for offset phase locking.

Using the PLL module integrated in the QuebeCL System, it will be sufficient to send the photodetector signal to the RF IN input and the module will add the correction signal directly to the laser current for phase/frequency stabilization. Through the control software it is possible to keep under control all the parameters for the optimization of the locking procedure.

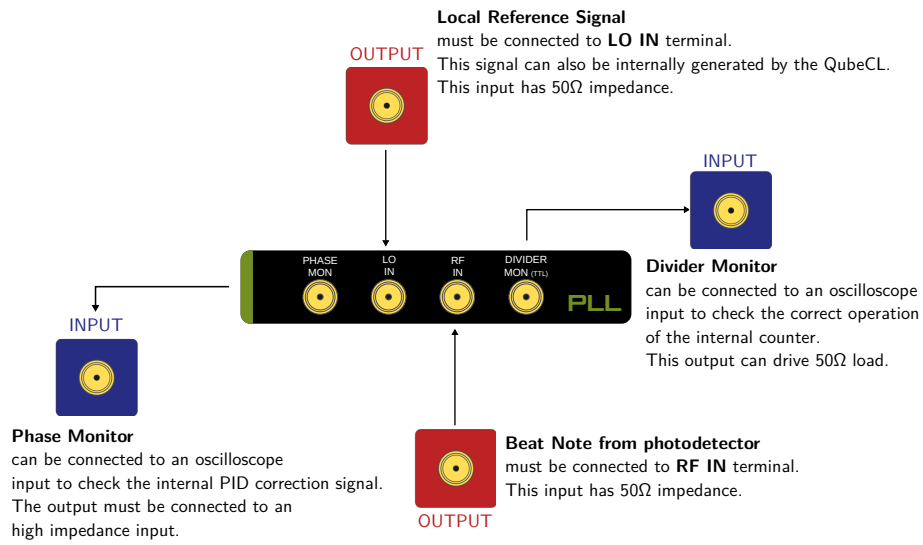

Figure 4: PLL terminals explanation

1.3 High-finesse cavity lock with PDH module

The Pound-Drever-Hall (PDH) technique is a method to lock the frequency of the radiation emitted from a laser to a resonance of a Fabry-Perot cavity. However stable the laser and cavity may be, both the length of the cavity and the frequency of the laser vary over time. The PDH locking technique uses the laser radiation reflected from the cavity to generate an error signal that can be used to either adjust the laser frequency or the cavity length so that they stay matched.

In the PDH technique the laser frequency is modulated, and its optical spectrum consists of a carrier frequency and two sidebands. The laser radiation reflected from the cavity is measured using a fast photodetector, the reflected signal consists of the two unaltered sidebands together with an out-of-phase carrier component.

The photodetector signal is mixed with a local oscillator, after adjustment of its phase. After low frequency filtering, the resulting demodulated signal has a dispersive line shape that can be used as error signal for active stabilization.

For high-finesse cavities, the frequency spacing of the sidebands can be of the order of MHz, in this situation the modulation can be applied directly on the laser current, without the need for external electro-optical modulators.

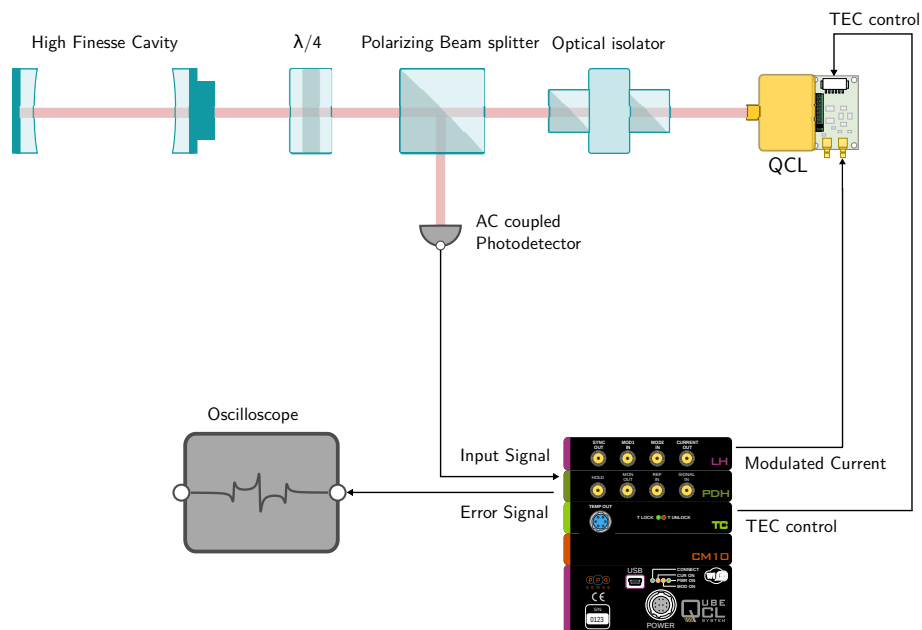

Figure 5: PDH cavity lock setup

The PDH module accepts as input the signal directly coming from the photodetector, processes it and applies the correction to perform the lock on the laser current. The control software allows to keep under control all the parameters for the optimization of the locking procedure.

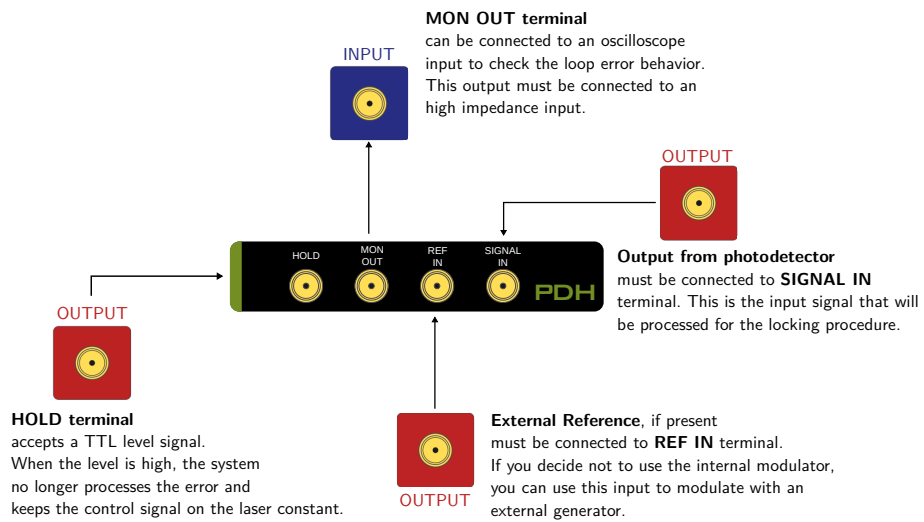

Figure 6: PDH terminals explanation